

SCHNEIDEISEN MIT SCHÄLANSCHNITT

Der Schälanschnitt bewirkt ein freies Abfließen der Späne nach vorne und eine Verringerung des Schnittmomentes. Spänestauungen in den Spanlöchern werden dadurch vermieden. Das Ergebnis ist eine verbesserte Oberflächengüte bei den geschnittenen Gewinden und eine höhere Standzeit des Werkzeuges.

Schneideisen, die auf Maschinen eingesetzt werden, müssen deshalb mit Schälanschnitt bestellt werden.



DIES WITH SPIRAL ENTRY

A spiral entry results in a free flow of chips ahead of the die and a reduction in the cutting torque. Blocking of the clearance holes by chips is avoided. This results in an improved surface finish on the cut threads and a longer die life.

Hence dies for machine use must be ordered with spiral entry.

HOCHLEISTUNGS-SCHNEIDEISEN

HIGH PERFORMANCE THREAD CUTTING DIES

N5110/N5120



mit Schälanschnitt ab \varnothing 3 mm
with spiral entry from \varnothing 3 mm

Runde Schneideisen aus HSS, nach DIN EN Norm

für Hand- oder Maschinengebrauch

- Für die Bearbeitung von Stahl bis 800 N/mm²
- Verschiedene Versionen zum Schneiden unterschiedlichster Werkstoffe

Round dies in HSS, as per DIN EN standards

for machine and manual use

- For machining steels up to 800 N/mm²
- Different versions for cutting a wide range of materials

Z5120



mit Schälanschnitt ab \varnothing 2 mm
with spiral entry from \varnothing 2 mm

Runde Schneideisen aus HSSE, nach DIN EN Norm

- Feine Spanaufteilung durch höhere Schneidstollenzahl und längeren Anschnitt 2 x P
- Für die Bearbeitung von rost- und säurebeständigen Stählen, Vergütungsstählen, Einsatzstählen usw. bis 1'200 N/mm² und kurzspanende ALU-Legierungen

Round dies in HSSE, as per DIN EN standards

• Fine chips due to more clearance holes and thus more cutting edges, and the extension of the chamfer to 2 x P

- For machining stainless steels, heat-treatable steels, case-hardening steels etc. up to 1'200 N/mm² and short-chipping ALU alloys

Z5120 LL Long Life



mit Schälanschnitt ab \varnothing 2 mm
with spiral entry from \varnothing 2 mm

Runde Schneideisen aus HSSE (ASP), nach DIN EN Norm

- Feinste Spanaufteilung durch höchste Schneidstollenzahl und längeren Anschnitt 2.25 x P
- Für Grossserien
- Long Life steht für enorme Standzeit
- Für die Bearbeitung von rost- und säurebeständigen Stählen, Vergütungsstählen, Einsatzstählen usw. bis 1'200 N/mm² und kurzspanende ALU-Legierungen

Round dies in HSSE (ASP), as per DIN EN standards

- Very fine chips due to maximum number of clearance holes and thus still more cutting edges, and the extension of the chamfer to 2.25 x P
- For the processing of large series
- Exceptionally long die life
- For machining stainless steels, heat-treatable steels, case-hardening steels etc. up to 1'200 N/mm² and short-chipping ALU alloys

MS5120



mit Schälanschnitt
with spiral entry

Runde Schneideisen aus HSS, nach DIN EN Norm

- Mit erweiterten Spanlöchern für bessere Spanabfuhr
- Für die Bearbeitung von kurzspanendem Messing

Round dies in HSS, as per DIN EN standards

- With enlarged clearance holes to prevent chips crowding
- For the machining of short-chipping brass

N5220 Z5220

MS5220



mit Schälanschnitt
with spiral entry

Automaten-Schneideisen aus HSS (Z = HSSE), mit 2 Aufschraublöchern

- Anwendungsgebiet entsprechend Typ N5120, MS5120 und Z5120
- Vorteil: durch die geringere Massenträgheit des Schneideisenhalters sind höhere Drehzahlen / Standzeiten möglich

Button dies for Swiss automatics, in HSS (Z = HSSE), with 2 securing holes

- Application area according to type N5120, MS5120 and Z5120
- Advantage: the low inertia of the die holder permits higher spindle speeds and extends die life

N5310



Sechskant-Schneideisen aus HSS, Baumassee nach DIN 382

- Zum Nachschneiden und Reparieren von beschädigten Gewinden oder zum Schneiden an schwer zugänglichen Stellen

Hexagon die nuts in HSS, general dimensions as per DIN 382

- For recutting and reclaiming damaged threads or for cutting threads in difficult locations

N5420



mit Schälanschnitt ab \varnothing 3 mm
with spiral entry from \varnothing 3 mm

Glockenform-Schneideisen aus HSS

- Vorteil: freies Abfließen der Späne und verbesserte Kühl-Schmiermittelzufuhr durch offene Spanräume, auch wenn nahe am Bund geschnitten wird

Bell form type thread cutting dies in HSS

- Advantage: free chip flow and improved coolant supply thanks to the open clearance holes, even when cutting threads close to shoulders

ANWENDUNGSTABELLE FÜR SCHNEIDEISEN

APPLICATION CHART FOR CUTTING DIES

Werkstoffbezeichnung	Werkstoffnummer	Schnittgeschwindigkeit m/min (Richtwerte)	Kühl-Schmiermittel	Spanwinkel	Schneideisentyp
Allgemeine Baustähle	St37-2, St50-2	8 - 12	Schneidöl	17 - 22°	N5...
Automatenstähle	9SMn28, 9SMnPb28	10 - 14	Schneidöl	17 - 22°	N5...
Einsatzstähle	C15, Ck15, 16MnCr5	6 - 10	Schneidöl / Spezial-Schneidöl	17 - 22°	Z5... / Z5... LL
Vergütungsstähle	C35Pb, C45	5 - 8	Schneidöl / Spezial-Schneidöl	13 - 18°	Z5... / Z5... LL
Rost- u. säurebeständige Stähle	X12CrMoS17, X12CrNiS188	4 - 6	Spezial-Schneidöl	13 - 18°	Z5... / Z5... LL
Messing kurzspanend, Ms 58	CuZn39Pb2, CuZn40Pb2	20 - 30	Schneidöl	6 - 11°	MS5...
Messing langspanend, Ms 60	CuZn20, CuZn37	12 - 18	Schneidöl	10 - 15°	N5...
Alu-Legierungen, kurzspanend	GD-ALSi8Cu3, GD-ALSi12	8 - 12	Spezial-Schneidöl, Petroleum	18 - 23°	Z5...
Reintitan	Ti2	5 - 8	Spezial-Schneidöl	19 - 24°	Z5... / Z5... LL

Schneideisen mit jeweils speziell angepasstem Spanwinkel für Grauguss, Messing bleifrei, Bronze, Rotguss, Kupfer, Alu-Legierungen langspanend sind als Spezialanfertigung lieferbar.

Auf Wunsch können wir auch Schneideisen in beschichteter Ausführung liefern. Preis und Lieferfrist auf Anfrage.

Material designation	Material Number	Cutting speed m/min (guide line)	Cutting fluid	Rake angle	Type of die
General engineering steels	St37-2, St50-2	8 - 12	Cutting oil	17 - 22°	N5...
Free-cutting steels	9SMn28, 9SMnPb28	10 - 14	Cutting oil	17 - 22°	N5...
Case hardening steels	C15, Ck15, 16MnCr5	6 - 10	Cutting oil / Special cutting oil	17 - 22°	Z5... / Z5... LL
Heat-treatable steels	C35Pb, C45	5 - 8	Cutting oil / Special cutting oil	13 - 18°	Z5... / Z5... LL
Stainless steels	X12CrMoS17, X12CrNiS188	4 - 6	Special cutting oil	13 - 18°	Z5... / Z5... LL
Short chip brass Ms 58	CuZn39Pb2, CuZn40Pb2	20 - 30	Cutting oil	6 - 11°	MS5...
Long chip brass Ms 60	CuZn20, CuZn37	12 - 18	Cutting oil	10 - 15°	N5...
Al-alloyed, short-chipping	GD-ALSi8Cu3, GD-ALSi12	8 - 12	Spezial cutting oil, Paraffin	18 - 23°	Z5...
Pure titanium	Ti2	5 - 8	Special cutting oil	19 - 24°	Z5... / Z5... LL

Cutting dies with specially adapted rake angle for grey cast iron, lead-free brass, bronze, gunmetal, copper and long-chipping aluminium alloys are available as special execution.

On request, we can also supply dies in a coated version. Price and delivery time on request.





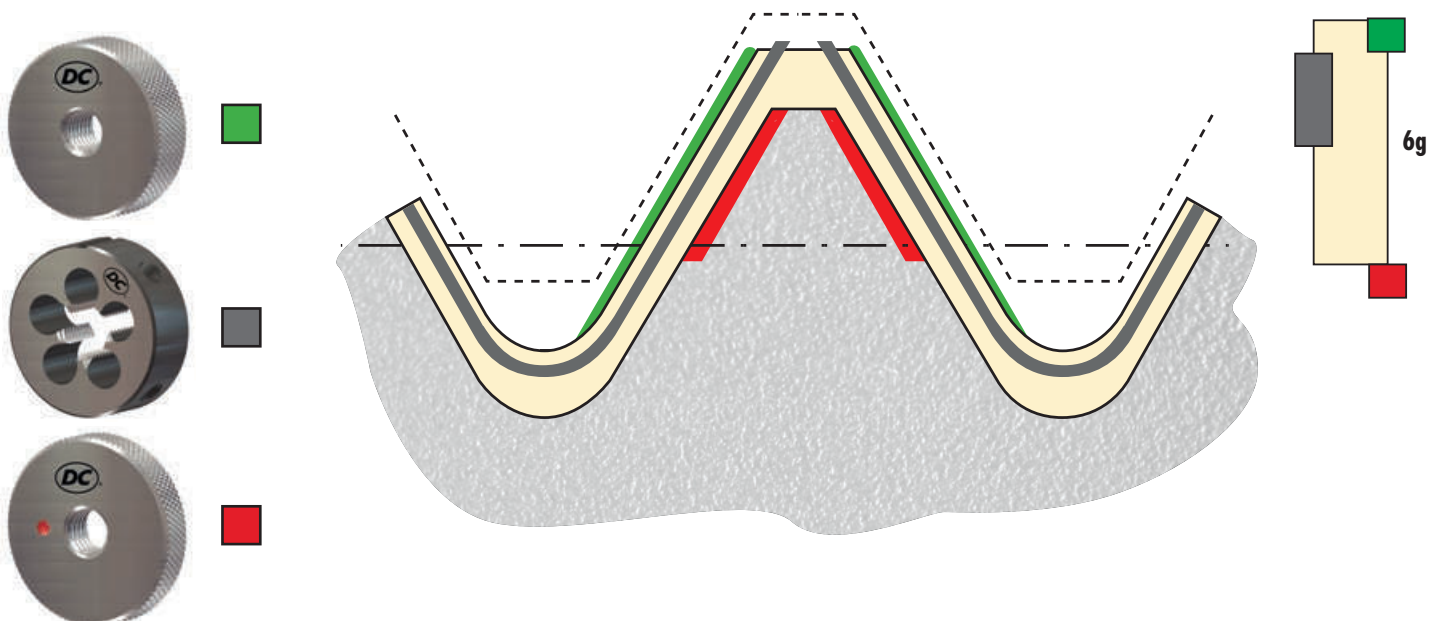



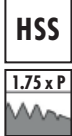

TOLERANZEN FÜR M- UND MF-GEWINDE

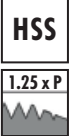
TOLERANCES FOR M AND MF THREADS

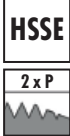

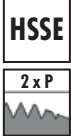
Inhaltsverzeichnis — Runde-, Automaten-, Sechskant- und Glocken-Schneideisen

Directory — Round dies, button dies for Swiss automatics, hexagon die nuts and bell form dies

		N		MS	Z		N	Z
Merkmale Characteristics			 	 	  	  	 	  
								
Typ Type		N5110	N5120	MS5120	Z5120	Z5120LL	N5220	Z5220
M 6g	ISO DIN 13	272	272		273	273	286	286
M 6e	ISO DIN 13		272				286	
M 6g LH	ISO DIN 13		272					
MF 6g	ISO DIN 13	274	274 - 276		274 - 275		287	
MF 6e	ISO DIN 13		274					
MF 6g LH	ISO DIN 13		274 - 276					
UNC	ASME B1.1	277	277					
UNF	ASME B1.1	278	278					
UNEF	ASME B1.1		279					
UN	ASME B1.1		279					
UNS	ASME B1.1		279					
G (BSP)	DIN EN ISO 228		280	281	281			
G (BSP) LH	DIN EN ISO 228		280					
G (BSP) -0.1mm	DIN EN ISO 228			281				
R (BSPT)	DIN EN 10226		282					
NPT	ASME B1.20.1		283					
NPTF	ANSI B1.20.3		283					
PG	DIN 40430		284					
TR	DIN 103		284					
W (BSW)	BS 84		285					
W (BSW) LH	BS 84		285					



Piktogramme - Pictographs

N	
N5310	N5420
288	289
288	
289	
289	

- HSS
HSS
- HSSE
HSSE
- 1.25 Gewindegänge
1.25 chamfered threads
- 1.75 Gewindegänge
1.75 chamfered threads
- 2 Gewindegänge
2 chamfered threads
- Schälanschnitt ab \varnothing 3 mm
Spiral entry from \varnothing 3 mm
- Schälanschnitt, beidseitig, ab \varnothing 3 mm
Spiral entry on both sides from \varnothing 3 mm
- Anzahl Spannuten
Number of flutes
- Vordrehdurchmesser
Turned diameters
- Nitriert ($d_1 \geq 3$ mm, $P \geq 0.5$ mm)
Nitrided ($d_1 \geq 3$ mm, $P \geq 0.5$ mm)
- Schneideisen mit 2 Aufschraublöchern
Die with 2 securing holes
- Toleranz 6g
Tolerance 6g
- Toleranz 6e
Tolerance 6e
- Toleranz "Medium Class"
Tolerance "Medium Class"
- Toleranz A
Tolerance A
- Konisches Gewinde 1:16 (NPT - NPTF - R)
Tapered thread 1:16 (NPT - NPTF - R)
- Linksgewinde
Left-hand thread

N5110								N5110		N5120		N5120 LH		N5120	
$\emptyset d_1$ M	P mm	d_2 mm	l_1 mm					ID	ID	ID	ID	6g - mm			
1	0.25	16	5	3		0.97		● 103851							
1.1	0.25	16	5	3		1.07		● 124659							
1.2	0.25	16	5	3		1.17		● 103852							
1.4	0.3	16	5	3		1.36		● 103853							
1.6	0.35	16	5	3		1.54		● 103855							
1.7	0.35	16	5	3		1.64		● 103856							
1.8	0.35	16	5	3		1.74		● 103857							
2	0.4	16	5	3		1.93		● 103864							
2.2	0.45	16	5	3		2.13		● 103867							
2.3	0.4	16	5	3		2.23		● 103869							
2.5	0.45	16	5	3		2.43		● 103872							
2.6	0.45	16	5	3		2.53		● 103876							
3	0.5	20	5	3	4	2.92	2.9	● 103879	● 104067	● 104068	● 104066	0.030			
3.5	0.6	20	5	3	4	3.41		● 103880	● 104071	● 104072					
4	0.7	20	5	3	4	3.91	3.87	● 103881	● 104114	● 104115	● 104113	0.035			
4.5	0.75	20	7	4		4.4		* 103882	● 104117						
5	0.8	20	7	4	4	4.9	4.87	● 103883	● 104146	● 104147	● 104145	0.035			
5.5	0.9	20	7	4		5.4		* 103884							
6	1	20	7	4	4	5.88	5.85	● 103885	● 104165	● 104166	● 104164	0.035			
7	1	25	9	4	4	6.88		● 103886	● 104174	● 104175					
8	1.25	25	9	4	4	7.87	7.83	● 103887	● 104186	● 104187	● 104185	0.035			
9	1.25	25	9	4		8.87		* 103888	● 104191						
10	1.5	30	11	4	4	9.85	9.82	● 103858	● 103953	● 103954	● 103952	0.035			
12	1.75	38	14	4	4	11.83	11.8	● 103859	● 103973	● 103974	● 103972	0.035			
14	2	38	14	4	4	13.82		● 103860	● 103989	● 103990					
16	2	45	18	4	4	15.82		● 103861	● 104003	● 104004					
18	2.5	45	18	5		17.79			● 104015						
20	2.5	45	18	5	5	19.79		● 103878	● 104028	● 104029					
22	2.5	55	22	5		21.79			● 104035						
24	3	55	22	5	5	23.76			● 104043	● 104044					
27	3	65	25	5		26.76			● 104058						
30	3.5	65	25	6	6	29.73			● 104079	● 104080					
33	3.5	65	25	6		32.73			● 104089						
36	4	65	25	7		35.7			● 104100						
								≤ M1.4							

Z5120		NI		13	14	21	Z5120	Z5120 LL			
Z5120 LL		NI		13	14	15					
$\emptyset d_1$ M	P mm	d_2 mm	l_1 mm	Z5120	Z5120LL	$\rightarrow 6g \leftarrow$	ID	ID			
2	0.4	16	3.5	4	4	1.93	● 125269	● 105115			
2.5	0.45	16	5	4	4	2.43	● 104779	● 105116			
2.6	0.45	16	5	4		2.53	★ 104780				
3	0.5	20	5	4	5	2.92	● 104788	● 105117			
3.5	0.6	20	5	4		3.41	● 104789				
4	0.7	20	5	4	5	3.91	● 104790	● 105118			
5	0.8	20	7	4	5	4.9	● 104792	● 105119			
6	1	20	7	4	5	5.88	● 104795	● 105120			
7	1	25	9	4		6.88	★ 111424				
8	1.25	25	9	5	6	7.87	● 104798	● 105121			
10	1.5	30	11	5	6	9.85	● 104767	● 105122			
12	1.75	38	14	5	6	11.83	● 104770	● 105123			
14	2	38	14	5		13.82	● 104773				
16	2	45	18	5		15.82	● 104776				
18	2.5	45	18	5		17.79	● 104778				
20	2.5	45	18	5		19.79	● 104783				
24	3	55	22	6		23.76	● 104787				















N5120								N5120	N5120 LH	N5120	Z5120	
Z5120												
								1.75 x P	1.75 x P	1.75 x P	2 x P	
								6g	6g	6e	6g	
Ø d ₁ MF	P mm	d ₂ mm	l ₁ mm	N	Z	≥6g _←	≥6e _←	ID	ID	ID	6g - mm	ID
*2	0.25	16	5	4		1.93		● 103863				
*2.5	0.35	16	5	4		2.44		● 103871				
3	0.35	20	5	4		2.94		● 104064				
3.5	0.35	20	5	4		3.44		● 104069				
4	0.35	20	5	4		3.94		● 104108				
4	0.5	20	5	4		3.93		● 104110				
4.5	0.5	20	5	4		4.43		● 104116				
5	0.5	20	5	4	4	4.93	4.9	● 104141	● 104142	● 104140	0.030	● 104791
5	0.75	20	7	4		4.9		● 104143				
5.5	0.5	20	5	4		5.43		● 104148				
6	0.5	20	5	4	4	5.93		● 104159	● 104160			● 104793
6	0.75	20	7	4	4	5.9		● 104162	● 104163			● 104794
7	0.5	25	9	4		6.93		● 104169				
7	0.75	25	9	4		6.9		● 104171				
8	0.5	25	9	5		7.93		● 104177				
8	0.75	25	9	4	4	7.9		● 104180				● 104796
8	1	25	9	4	4	7.88	7.85	● 104183	● 104184	● 104182	0.035	● 104797
9	0.5	25	9	5		8.93		● 104188				
9	0.75	25	9	5		8.9		● 104189				
9	1	25	9	5		8.88		● 104190				
10	0.5	30	11	5		9.93		● 103942				
10	0.75	30	11	5	5	9.9		● 103945				● 104765
10	1	30	11	5	5	9.88	9.85	● 103948	● 103949	● 103947	0.035	● 104766
10	1.25	30	11	4		9.86		● 103950	● 103951			
11	0.75	30	11	5		10.9		● 103956				
11	1	30	11	5		10.88		● 103957				
11	1.25	30	11	5		10.86		● 103958				
12	0.5	38	10	5		11.93		● 103960				
12	0.75	38	10	5		11.9		● 103962				
12	1	38	10	5	5	11.88	11.85	● 103965	● 103966	● 103964	0.035	● 104768
12	1.25	38	10	4		11.86		● 103967	● 103968			
12	1.5	38	10	4	5	11.85		● 103970	● 103971			● 104769
13	1	38	10	5		12.88		● 103976				
* N5110								P 0.25 6h				

MF ISO DIN 13

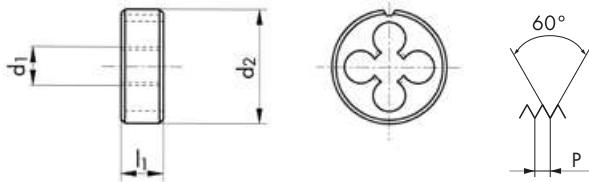









N Z
HSS HSSE

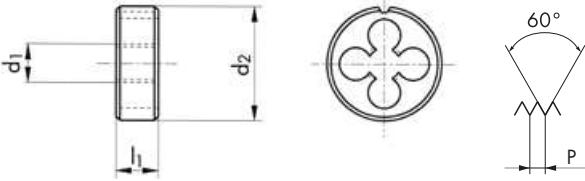

N5120							N5120	N5120 LH	Z5120
Ø d ₁ MF	P mm	d ₂ mm	l ₁ mm	N	Z	→6g←	ID	ID	ID
14	0.5	38	10	5		13.93	● 103977		
14	0.75	38	10	5		13.9	● 103979		
14	1	38	10	5	5	13.88	● 103981	● 103982	● 104771
14	1.25	38	10	5		13.86	● 103983		
14	1.5	38	10	5	5	13.85	● 103986	● 103987	● 104772
15	1	38	10	5		14.88	● 103991		
15	1.5	38	10	5		14.85	● 103992		
16	1	45	14	5	5	15.88	● 103996	● 103997	● 104774
16	1.25	45	14	5		15.86	● 103998		
16	1.5	45	14	5	5	15.85	● 104000	● 104001	● 104775
17	1	45	14	5		16.88	● 104005		
18	1	45	14	5		17.88	● 104008		
18	1.5	45	14	5		17.85	● 104011	● 104012	
18	2	45	14	5		17.82	● 104013		
19	1	45	14	6		18.88	● 104017		
20	1	45	14	6	6	19.88	● 104021	● 104022	● 104781
20	1.5	45	14	6	6	19.85	● 104024	● 104025	● 104782
20	2	45	14	6		19.82	● 104026		
21	1	45	14	7		20.88	● 111386		
22	1	55	16	6		21.88	● 104030		
22	1.5	55	16	5		21.85	● 104032		
22	2	55	16	5		21.82	● 104034		
23	1	55	16	6		22.88	● 121704		
24	1	55	16	6		23.88	● 104037		
24	1.5	55	16	6		23.85	● 104039		
24	2	55	16	6		23.82	● 104041	● 104042	
25	1	55	16	6		24.88	● 104045		
25	1.5	55	16	6		24.85	● 104046		
26	1	55	16	7		25.88	● 104049		
26	1.5	55	16	6		25.85	● 104050		
26	2	55	16	6		25.82	● 104052		
27	1	65	18	6		26.88	● 104053		
27	1.5	65	18	6		26.85	● 104054		
27	2	65	18	6		26.82	● 104056		

						N5120	N5120 LH		
<p>N5120   </p> <p>N5120 LH    </p>									
									
$\emptyset d_1$ MF	P mm	d_2 mm	l_1 mm		 →6g←	ID	ID		
28	1	65	18	6	27.88	● 104060			
28	1.5	65	18	6	27.85	● 104061			
30	1	65	18	7	29.88	● 104073			
30	1.5	65	18	6	29.85	● 104074			
30	2	65	18	6	29.82	● 104076			
32	1.5	65	18	7	31.85	● 104082	* 104083		
33	1.5	65	18	7	32.85	● 104085			
33	2	65	18	7	32.82	● 104086			
34	1.5	65	18	7	33.85	● 104091			
35	1.5	65	18	8	34.85	● 104092			
36	1.5	65	18	8	35.85	● 104095			
36	2	65	18	8	35.82	● 104097			
36	3	65	25	7	35.76	● 104099			
38	1.5	75	20	7	37.85	● 104101			
39	1.5	75	20	7	38.85	● 104104			
40	1.5	75	20	8	39.85	● 104118			
40	2	75	20	7	39.82	● 104120			
42	1.5	75	20	8	41.85	● 104122			
42	3	75	20	8	41.76	● 104125			
45	1.5	90	22	7	44.85	● 104127			
45	2	90	22	7	44.82	● 104129			
48	1.5	90	22	8	47.85	● 104133	* 104134		
48	2	90	22	8	47.82	● 104135			
48	3	90	22	7	47.76	● 104137			
50	1.5	90	22	8	49.85	● 104150			
60	2	105	22	9	59.82	● 104168			







							N5110	N5120		
<p>N5110 </p> <p>N5120  </p>										
							 		 	
Ø" d ₁ UNC	P TPI	d ₁ mm	d ₂ mm	l ₁ mm			ID	ID		
1	64	1.85	16	5	3	1.79	● 103893			
2	56	2.18	16	5	4	2.12	● 103894			
3	48	2.51	16	5	4	2.44	● 103895			
4	40	2.84	16	5	4	2.76	● 103896			
5	40	3.17	20	5	4	3.09		● 104263		
6	32	3.5	20	7	4	3.41		● 104266		
8	32	4.16	20	7	4	4.07		● 104269		
10	24	4.82	20	7	4	4.71		● 104258		
12	24	5.48	20	7	4	5.37		● 104259		
1/4	20	6.35	20	7	4	6.22		● 104256		
5/16	18	7.93	25	9	4	7.8		● 104264		
3/8	16	9.52	30	11	4	9.37		● 104262		
7/16	14	11.11	30	11	4	10.95		● 104267		
1/2	13	12.7	38	14	4	12.52		● 111387		
9/16	12	14.28	38	14	4	14.1		● 104270		
5/8	11	15.87	45	18	4	15.68		● 104265		
3/4	10	19.05	45	18	5	18.84		● 104261		
7/8	9	22.22	55	22	5	22		● 104268		
1	8	25.4	55	22	5	25.16		● 104257		
1 1/4	7	31.75	65	25	6	31.49		● 104251		
1 1/2	6	38.1	75	30	6	37.81		● 104250		
2	4.5	50.8	90	36	7	50.45		★ 104260		

							N5110	N5120		
<p>N5110 </p> <p>N5120 </p> <p></p>										
Ø" d ₁ UNF	P TPI	d ₁ mm	d ₂ mm	l ₁ mm			ID	ID		
0	80	1.52	16	5	3	1.47	● 103897			
1	72	1.85	16	5	3	1.79	● 103898			
2	64	2.18	16	5	4	2.12	● 103899			
3	56	2.51	16	5	4	2.44	● 103900			
4	48	2.84	16	5	4	2.77	● 103901			
5	44	3.17	20	5	4	3.1		● 104299		
6	40	3.5	20	5	4	3.42		● 104302		
8	36	4.16	20	7	4	4.08		● 104305		
10	32	4.82	20	7	4	4.73		● 104295		
12	28	5.48	20	7	4	5.38		● 104296		
1/4	28	6.35	20	7	4	6.24		● 104293		
5/16	24	7.93	25	9	4	7.82		● 104300		
3/8	24	9.52	30	11	4	9.41		● 104298		
7/16	20	11.11	30	11	5	10.98		● 104303		
1/2	20	12.7	38	10	5	12.56		● 104292		
9/16	18	14.28	38	10	5	14.14		● 104306		
5/8	18	15.87	45	14	5	15.73		● 104301		
3/4	16	19.05	45	14	6	18.89		● 104297		
7/8	14	22.22	55	16	5	22.05		● 104304		
1	12	25.4	55	16	6	25.21		● 104294		
1 1/4	12	31.75	65	18	7	31.56		● 104289		
1 1/2	12	38.1	75	20	7	37.91		● 111390		

UNEF, UNS, UN ASME B1.1

HSS

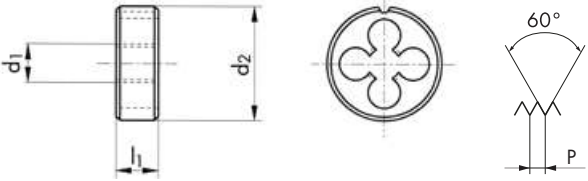











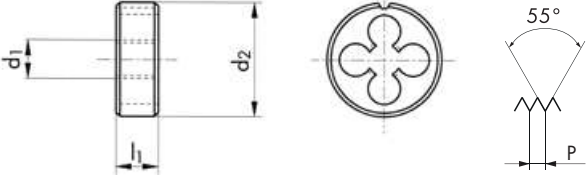

N5120							N5120			
 										
							 			
Ø" d ₁ UNEF	P TPI	d ₁ mm	d ₂ mm	l ₁ mm	+	→2A←	ID			
12	32	5.48	20	7	4	5.39	● 104278			
1/4	32	6.35	20	7	4	6.25	● 104275			
5/16	32	7.93	25	9	4	7.84	● 104283			
3/8	32	9.52	30	11	4	9.42	● 104282			
7/16	28	11.11	30	11	5	11	● 104285			
1/2	28	12.7	38	10	5	12.59	● 104274			
9/16	24	14.28	38	10	5	14.17	● 104287			
5/8	24	15.87	45	14	5	15.75	● 104284			
3/4	20	19.05	45	14	6	18.91	● 104281			
Ø" d ₁ UNS	P TPI	d ₁ mm	d ₂ mm	l ₁ mm	+	→2A←	ID			
1/4	40	6.35	20	5	4	6.26	● 104309			
1/4	36	6.35	20	5	4	6.26	● 104308			
7/16	24	11.11	30	11	5	10.99	● 104311			
1/2	24	12.7	38	10	5	12.58	● 104307			
1	14	25.4	55	16	6	25.23	● 104310			
Ø" d ₁ UN	P TPI	d ₁ mm	d ₂ mm	l ₁ mm	+	→2A←	ID			
1 1/8	8	28.57	65	25	5	28.33	● 104246			
1 1/4	8	31.75	65	25	6	31.51	● 104245			
1 1/2	8	38.1	75	20	7	37.85	● 104244			
1 3/4	8	44.45	90	22	7	44.2	● 104247			

G DIN EN ISO 228 (BSP)

HSS















							N5120	N5120 LH		
N5120  $\geq \emptyset 3$ 										
N5120 LH  $\geq \emptyset 3$  										
										
\emptyset " d ₁ G	P TPI	d ₁ mm	d ₂ mm	l ₁ mm			ID	ID		
1/8	28	9.7	30	11	5	9.62	● 103926			
1/4	19	13.15	38	10	5	13.03	● 103924	● 103925		
3/8	19	16.66	45	14	5	16.54	● 103935	● 103936		
1/2	14	20.95	45	14	6	20.81	● 103922	● 103923		
5/8	14	22.91	55	16	5	22.77	● 103938			
3/4	14	26.44	55	16	6	26.3	● 103933	● 103934		
7/8	14	30.2	65	18	6	30.06	● 103940			
1	11	33.24	65	18	7	33.07	● 103928			
1 1/4	11	41.91	75	20	8	41.73	● 103918			
1 1/2	11	47.8	90	22	8	47.62	● 103917			
2	11	59.61	105	22	9	59.43	● 103932			
2 1/2	11	75.18	120	22	10	74.97	● 103930			

G DIN EN ISO 228 (BSP)

Z MS
HSSE HSS



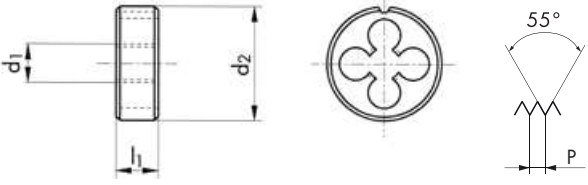





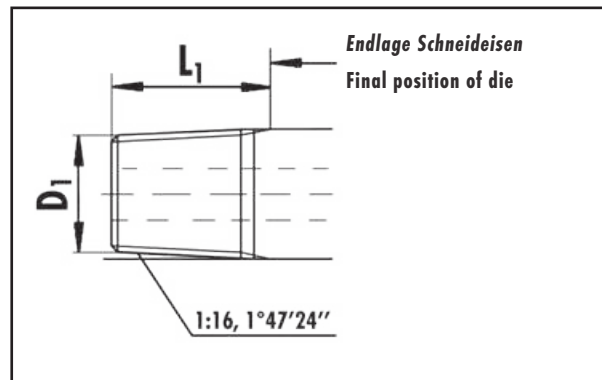



Z5120		NI	13	14	21	Z5120	MS5120	MS5120		
MS5120										
MS5120						 	 	 		
										
\emptyset " d ₁ G	P TPI	d ₁ mm	d ₂ mm	l ₁ mm	Z	MS	\rightarrow A \leftarrow	ID	ID	ID
1/8	28	9.72	30	11	5	5	9.62	● 104761		★ 142831
1/4	19	13.15	38	10	5	5	13.03	● 104760	● 101338	★ 142832
3/8	19	16.66	45	14	5	5	16.54	● 104764	● 101342	● 119716
1/2	14	20.95	45	14	6	6	20.81	● 104759	● 101337	● 119243
3/4	14	26.44	55	16	6	6	26.3	● 104763	● 101341	● 119648
1	11	33.24	65	18	8	7	33.07	● 104762	● 101340	● 135186

N5120					N5120
$\varnothing'' d_1$ R	P TPI	d_2 mm	l_1 mm		ID
1/8	28	30	11	5	● 104226
1/4	19	38	14	5	● 104225
3/8	19	45	14	5	● 104230
1/2	14	45	18	6	● 104224
3/4	14	55	22	6	● 104229
1	11	65	25	7	● 104227

Richtwerte für Drehdurchmesser für R-Gewinde (in mm)
Guide values for turning diameters for R-threads (in mm)

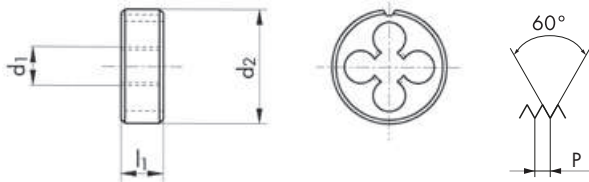
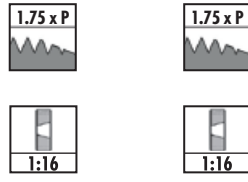

\varnothing'' R	D_1 mini mm	D_1 maxi mm	D_1 (guide line) mm	L_1 (guide line) mm
1/8	9.422	9.534	9.48	8.2
1/4	12.700	12.863	12.78	12.1
3/8	16.181	16.343	16.26	12.5
1/2	20.330	20.555	20.44	16.4
3/4	25.735	25.960	25.85	17.7
1	32.455	32.743	32.60	20.9

<p>N5120    </p>					N5120	N5120		
<p>N5120    </p>					<p>NPT NPTF</p> 			
								
$\varnothing'' d_1$ NPT, NPTF	P TPI	d_2 mm	l_1 mm		ID	ID		
1/16	27	25	9	4	● 104194			
1/8	27	30	11	5	● 104197			
1/4	18	38	14	5	● 104196			
3/8	18	45	14	5	● 104201			
1/2	14	45	18	6	● 104195	* 104205		
3/4	14	55	22	6	● 104200			
1	11.5	65	25	7	● 104198	* 104208		
1 1/4	11.5	75	26	8	● 104193			

Richtwerte für Drehdurchmesser für NPT- und NPTF-Gewinde (in mm)
Guide values for turning diameters for NPT and NPTF-threads (in mm)

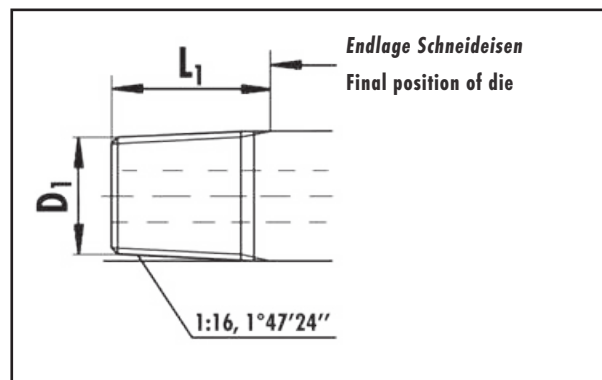

\varnothing'' NPT	D_1 mini mm	D_1 maxi mm	D_1 (guide line) mm	L_1 (guide line) mm	\varnothing'' NPTF	D_1 mini mm	D_1 maxi mm	D_1 (guide line) mm	L_1 (guide line) mm
1/16	7.521	7.643	7.58	8.4	1/16	7.525	7.617	7.57	8.4
1/8	9.866	9.988	9.93	8.5	1/8	9.870	9.962	9.92	8.5
1/4	13.099	13.255	13.18	12.7	1/4	13.129	13.215	13.17	12.7
3/8	16.518	16.674	16.60	12.9	3/8	16.548	16.634	16.59	12.9
1/2	20.551	20.713	20.63	16.8	1/2	20.617	20.703	20.66	16.8
3/4	25.866	26.028	25.95	17.1	3/4	25.932	26.018	25.98	17.1
1	32.419	32.591	32.51	21.3	1	32.475	32.561	32.52	21.3
1 1/4	41.144	41.316	41.23	21.9					

PG DIN 40430 TR DIN 103

HSS















N5120							N5120	N5120			
							<div style="display: flex; justify-content: space-around;"> <div style="border: 1px solid black; padding: 5px;">PG</div> <div style="border: 1px solid black; padding: 5px;">TR</div> </div>				
Ø d ₁ PG	P TPI	d ₁ mm	d ₂ mm	l ₁ mm			ID				
7	20	12.5	38	10	5	12.4	● 104220				
9	18	15.2	38	10	5	15.1	● 104221				
11	18	18.6	45	14	5	18.5	● 104212				
13.5	18	20.4	45	14	6	20.3	● 104213				
16	18	22.5	55	16	5	22.4	● 104214				
42	16	54	90	22	10	53.85	* 104218				
48	16	59.3	105	22	9	59.15	* 104219				
Other sizes on request!											
							<div style="border: 1px solid black; padding: 5px; width: fit-content; margin: 0 auto;">7e</div>				
Ø d ₁ TR	P mm	d ₂ mm	l ₁ mm			ID	ID				
28	5	65	25	5	27.83	* 104240					
32	6	65	25	6	31.81	* 104242					
Other sizes on request!											

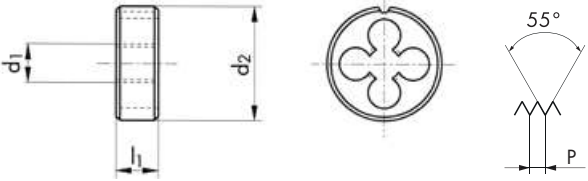

















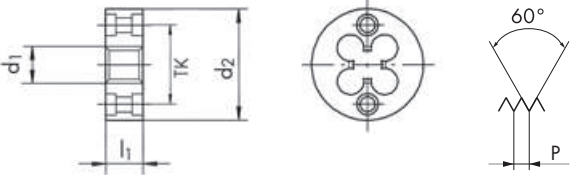

W BS 84 (BSW)

HSS



							N5120	N5120 LH		
<p>N5120  </p> <p>N5120 LH   </p>										
										
\emptyset W	d_1	P	d_2	l_1			ID	ID		
1/8	40	3.17	20	5	4	3.09	● 104320			
5/32	32	3.96	20	7	4	3.88	● 104333			
3/16	24	4.76	20	7	4	4.66	● 104325			
1/4	20	6.35	20	7	4	6.24	● 104318			
5/16	18	7.93	25	9	4	7.82	● 104331			
3/8	16	9.52	30	11	4	9.4	● 104329			
7/16	14	11.11	30	11	4	10.98	● 104336			
1/2	12	12.7	38	14	4	12.56	● 104316			
5/8	11	15.87	45	18	4	15.72	● 104334			
3/4	10	19.05	45	18	5	18.89	● 104327	* 104328		
1	8	25.4	55	22	5	25.27	● 104322			
1 3/8	6	34.92	65	25	6	34.77	* 104315			



								N5220	N5220	Z5220	
<p>N5220   </p> <p>N5220   </p> <p>Z5220    </p>											
											
											
$\emptyset d_1$ M	P mm	d_2 mm	l_1 mm		TK mm			ID	ID	6g - mm	ID
1.4	0.3	16	2.6	4	12.2	1.36		● 104346			
1.6	0.35	16	2.6	4	12.2	1.54		● 104347			
2	0.4	16	3.5	4	12.2	1.93		● 104367			
2.3	0.4	16	3.5	4	12.2	2.23		● 104369			
2.5	0.45	16	3.5	4	12.2	2.43		● 104371		● 104803	
2.6	0.45	16	3.5	4	12.2	2.53		● 104372			
3	0.5	16	3.5	4	12.2	2.92	2.9	● 104375	● 104374	0.030	● 104804
3.5	0.6	16	4	4	12.2	3.41		● 104376			
4	0.7	16	5	4	12.2	3.91	3.87	● 104380	● 104379	0.035	● 104805
5	0.8	20	7	4	15	4.9	4.87	● 104384	● 104383	0.035	● 104806
6	1	20	7	4	15	5.88	5.85	● 104388	● 104387	0.035	● 104807
8	1.25	25	9	4	19	7.87	7.83	● 104397	● 104396	0.035	● 104808
10	1.5	30	11	6	23	9.85	9.82	● 104354	● 104353	0.035	
12	1.75	30	11	6	23	11.83		● 104358			

≤ M1.4

6h



N5220							N5220	
$\varnothing d_1$ MF	P mm	d_2 mm	l_1 mm		TK mm	 6g	ID	
3	0.35	16	3	4	12.2	2.94	● 104373	
4	0.5	16	4	4	12.2	3.93	● 104378	
5	0.5	20	5	4	15	4.93	● 104382	
6	0.5	20	5	4	15	5.93	● 104385	
6	0.75	20	7	4	15	5.9	● 104386	
7	0.5	25	7	4	19	6.93	* 104389	
7	0.75	25	7	4	19	6.9	* 104390	
10	0.75	30	7	6	23	9.9	* 104350	
10	1.25	25	9	6	19	9.86	* 104352	

N5310						N5310						
$\emptyset d_1$ M	P mm	s mm	l_1 mm			ID						
3	0.5	18	5	3	2.92	●	104464					
3.5	0.6	18	5	3	3.41	★	104465					
4	0.7	18	5	3	3.91	●	104478					
4.5	0.75	18	7	3	4.41	★	104479					
5	0.8	18	7	4	4.9	●	104487					
6	1	18	7	4	5.88	●	104493					
8	1.25	21	9	4	7.87	●	104502					
9	1.25	21	9	5	8.87	★	104503					
10	1.5	27	11	4	9.85	●	104438					
12	1.75	36	14	4	11.83	●	104443					
14	2	36	14	4	13.82	●	104445					
16	2	41	18	4	15.82	●	104447					
18	2.5	41	18	5	17.79	●	104450					
20	2.5	41	18	5	19.79	●	104453					
22	2.5	50	22	5	21.79	●	104456					
24	3	50	22	5	23.76	●	104459					
30	3.5	60	25	5	29.73	●	104468					
$\emptyset d_1$ MF	P mm	s mm	l_1 mm			ID						
6	0.75	18	7	4	5.9	★	104492					
8	0.75	21	9	4	7.9	★	104500					
8	1	21	9	4	7.88	★	104501					
12	1	36	10	4	11.88	★	104440					
27	1.5	60	18	6	26.85	★	104461					
33	1.5	60	18	7	32.85	★	104469					
39	1.5	70	20	8	38.85	★	104476					

G DIN EN ISO 228 (BSP)

W BS 84 (BSW)

M ISO DIN 13

HSS



							N5310	N5310		N5420		
N5310												
N5310												
N5420												
\emptyset " d ₁ G	P TPI	d ₁ mm	s mm	l ₁ mm			ID					
1/4	19	13.15	36	10	5	13.03	● 104428					
3/8	19	16.66	41	14	5	16.54	● 104433					
1/2	14	20.95	41	14	6	20.81	● 104427					
5/8	14	22.91	50	16	6	22.77	★ 104434					
3/4	14	26.44	50	16	6	26.3	● 104432					
7/8	14	30.2	60	18	6	30.06	★ 104435					
1	11	33.24	60	18	7	33.07	● 104430					
1 3/8	11	44.32	85	22	7	44.14	★ 104426					
1 3/4	11	53.74	100	22	8	53.57	★ 104425					
\emptyset " d ₁ W	P TPI	d ₁ mm	s mm	l ₁ mm			ID					
1/8	40	3.17	18	5	3	3.09	★ 104512					
3/16	24	4.76	18	7	3	4.66	★ 104515					
9/16	12	14.28	36	14	4	14.14	★ 104522					
1 3/8	6	34.92	60	25	6	34.77	★ 104508					
1 1/2	6	38.1	70	30	6	37.95	★ 104504					
1 3/4	5	44.45	85	36	6	44.28	★ 104507					
2	4.5	50.8	85	36	7	50.63	★ 104514					
\emptyset d ₁ M	P mm	d ₂ mm	l ₁ mm			ID						
2.5	0.45	16	8	4	2.43	★ 104527						
3.5	0.6	16	9.5	4	3.41	★ 104530						
8	1.25	25	14	5	7.86	★ 104535						